

# FROSTLINE®

**FROST- PROOF AUTOMATIC DRINKING SYSTEM**  
FRESH WATER SUPPLY FOR HORSES ALL YEAR ROUND  
WITHOUT THE USE OF ELECTRICITY



[www.frostline.dk](http://www.frostline.dk)

## FROST-PROOF AUTOMATIC DRINKING SYSTEM FOR HORSES

The automatic drinking systems are particularly suitable for corrals and open fields or for open box and stable facilities. The bowls are easy to operate and the horses quickly learn that it is more comfortable to push with the root of their noses rather than with their muzzles. When the muzzle is free for drinking, the horse will drink naturally with its muzzle in the water surface. Therefore, we have chosen a bowl that is wide and deep to provide a good water surface to drink from.

The drinking system is fitted with a patented self-emptying sliding valve ensuring that the tap remains frost proof even at hard freezing temperatures. The seals can be replaced without digging up the well. Pull the system out of the well, dismantle the valve and change the seals (o-rings).

### PRODUCT

Designation: Automatic drinking system A362 and A382.  
 Supplied complete with well  
 Tapping: D8mm supply nozzle  
 Connection: ½" nipple pipe thread

### INSTALLATION DIMENSIONS

	A362	A382
Height to bowl (H2):	600mm	800mm
Pipe stand height (H3):	660mm	860mm
Overall height (H1):	1560mm	1760mm
Well:	D200 x 900mm	D200 x 900mm

### SHIPPING

Dimensions, H-W-D: 1560 x 275 x 348mm/ 1760 x 275 x 348mm  
 Weight: 8,5kg/ 9,0kg - complete with well

### VALVE

FROSTLINE® self-emptying sliding valve  
 Capacity: 9 l/min. at 2-4 bar  
 connection pressure: 2-6 bar  
 O-rings: NBR - 1 x D9x1,5 70sh, 2 x D6x1,5 70sh

### MODELS

A362	69.48.91.360	Automatic Drinking System 60cm
A382	69.48.91.380	Automatic Drinking System 80cm

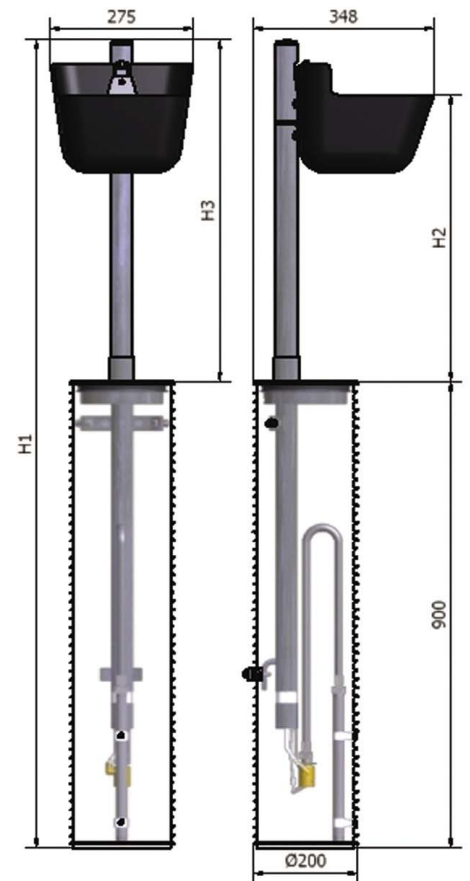

### OPERATION OF THE VALVE

The system is provided with a 3-way self-emptying sliding valve. When the system is not in use, the valve and riser pipe are emptied of water that might otherwise freeze. The drinking system and thus the valve and riser pipe are frost-proof as long as the water supply line for the system is at frost-free depth.

### RECOMMENDATION

A automatic drinking system can provide fresh, cool drinking water all year round for 10-12 horses but we recommend installation of two systems with a minimum distance of 5 meters between the two, when more than one horse is to be served in order to secure that all horses have access to the water. This means that the two systems can serve a total of 20-24 horses.



# FROSTLINE®

**FROST- PROOF AUTOMATIC DRINKING SYSTEM**  
FRESH WATER SUPPLY FOR HORSES - ALL YEAR ROUND  
WITHOUT THE USE OF ELECTRICITY



[www.frostline.dk](http://www.frostline.dk)

## FROST-PROOF AUTOMATIC DRINKING SYSTEM FOR CATTLE

The automatic drinking systems are particularly suitable for corrals and open fields or for open stable facilities. The bowls are easy to operate, and the cattle quickly learn that it is more comfortable to push with the root of their noses rather than with their muzzles. When the muzzle is free for drinking, the cattle will drink naturally with its muzzle in the water surface. Therefore, we have chosen a bowl that is wide and deep to provide a good water surface to drink from.

The drinking system is fitted with a patented self-emptying sliding valve ensuring that the tap remains frost proof even at hard freezing temperatures. The seals can be replaced without digging up the well. Pull the system out of the well, dismantle the valve and change the seals (o-rings)

### PRODUCT

Designation: Automatic drinking system A342 and A362.  
 Supplied complete with well  
 Tapping: D8mm supply nozzle  
 Connection: ½" nipple pipe thread

### INSTALLATION DIMENSIONS

	A342	A362
Height to bowl (H2):	400mm	600mm
Pipe stand height (H3):	460mm	660mm
Overall height (H1):	1360mm	1560mm
Well:	D200 x 900mm	D200 x 900mm

### SHIPPING

Dimensions, H-W-D: 1360 x 275 x 348mm/ 1560 x 275 x 348mm  
 Weight: 8,0kg/ 8,5kg - complete with well

### VALVE

FROSTLINE® self-emptying sliding valve  
 Capacity: 9 l/min. at 2-4 bar  
 connection pressure: 2-6 bar  
 O-rings: NBR - 1 x D9x1,5 70sh, 2 x D6x1,5 70sh

### MODELS

A342	69.48.91.340	Automatic Drinking System 40cm
A362	69.48.91.360	Automatic Drinking system 60cm

### OPERATION OF THE VALVE

The system is provided with a 3-way self-emptying sliding valve. When the system is not in use, the valve and riser pipe are emptied of water that might otherwise freeze. The drinking system and thus the valve and riser pipe are frost-proof as long as the water supply line for the system is at frost-free depth.

### RECOMMENDATION

A automatic drinking system can provide fresh, cool drinking water all year round for 10-12 cattle but we recommend installation of two systems with a minimum distance of 5 meters between the two, when more than one is to be served in order to secure that all cattle have access to the water. This means that the two systems can serve a total of 20-24 cattle.

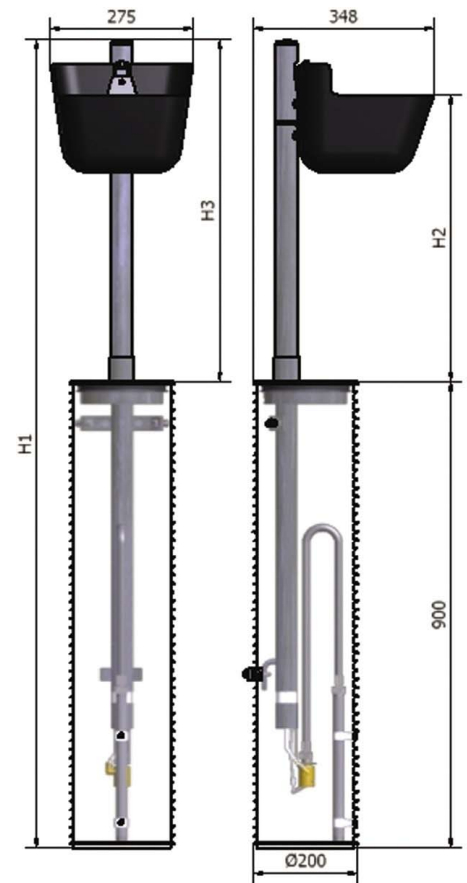

# FROSTLINE®

**FROST- PROOF AUTOMATIC DRINKING SYSTEM**  
FRESH WATER SUPPLY FOR FREE RANGE PIGS ALL YEAR ROUND  
- WITHOUT THE USE OF ELECTRICITY



[www.frostline.dk](http://www.frostline.dk)

## FROST-PROOF AUTOMATIC DRINKING SYSTEM FOR FREE RANGE PIGS

FROSTLINE® automatic drinking systems ensure fresh, cool water for pigs regardless of the weather, all year round. In winter, the pigs can drink as needed, which means a minimum of work with the water supply. In summer, there are no huge tubs filled with stale water that require changing and cleaning due to algae.

The drinking bowl is made from stainless steel and is quite deep. The pigs operate the system by pressing with the root of their noses instead of their snouts. This assures a water surface which allows the pigs to drink naturally.

The design and functionality of the bowl makes it possible to reduce water wastage to a minimum.

The drinking system is fitted with a patented self-emptying sliding valve ensuring that the tap remains frost proof even at hard freezing temperatures. The seals can be replaced without digging up the well. Pull the system out of the well, dismantle the valve and change the seals (o-rings).

### PRODUCT

Designation: Automatic drinking system A640.  
Supplied complete with well  
Tapping: D8mm supply nozzle  
Connection: ½" nipple pipe thread

### INSTALLATION DIMENSIONS

Height to bowl: 170mm  
Pipe stand height: 365mm  
Overall height: 1265mm  
Well: D200 x 900mm

### SHIPPING

Dimensions, H-W-D: 1280 x 200 x 238mm  
Weight: 9,0kg - complete with well

### VALVE

FROSTLINE® self-emptying sliding valve  
Capacity: 9 l/min. at 2-4 bar  
connection pressure: 2-6 bar  
O-rings: NBR - 1 x D9x1,5 70sh, 2 x D6x1,5 70sh

MODEL		
A640	69.48.91.120	Automatic Drinking system

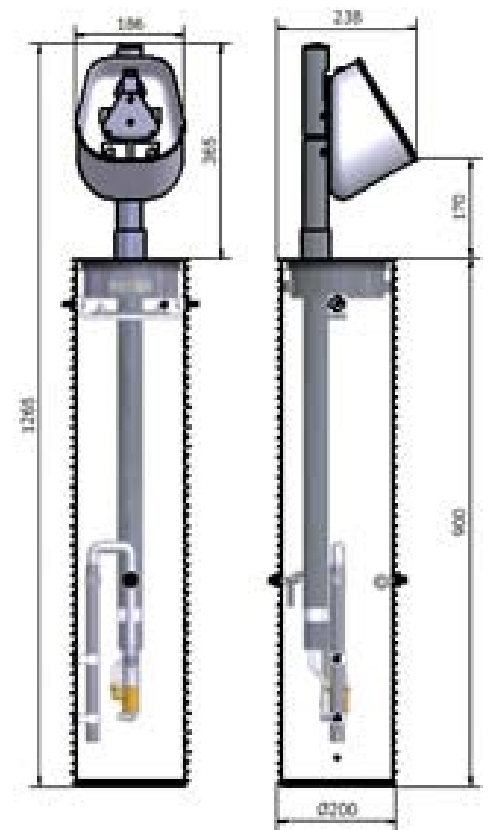

### OPERATION OF THE VALVE

The system is provided with a 3-way self-emptying sliding valve. When the system is not in use, the valve and riser pipe are emptied of water that might otherwise freeze. The drinking system and thus the valve and riser pipe are frost-proof as long as the water supply line for the system is at frost-free depth.

