

FROSTLINE®

FROST- PROOF AUTOMATIC DRINKING SYSTEM
FRESH WATER SUPPLY FOR HORSES ALL YEAR ROUND
WITHOUT THE USE OF ELECTRICITY



www.frostline.dk

FROST-PROOF AUTOMATIC DRINKING SYSTEM FOR HORSES

The automatic drinking systems are particularly suitable for corrals and open fields or for open box and stable facilities. The bowls are easy to operate and the horses quickly learn that it is more comfortable to push with the root of their noses rather than with their muzzles. When the muzzle is free for drinking, the horse will drink naturally with its muzzle in the water surface. Therefore, we have chosen a bowl that is wide and deep to provide a good water surface to drink from.

The drinking system is fitted with a patented self-emptying sliding valve ensuring that the tap remains frost proof even at hard freezing temperatures. The seals can be replaced without digging up the well. Pull the system out of the well, dismantle the valve and change the seals (o-rings).

PRODUCT

Designation: Automatic drinking system A362 and A382.
 Supplied complete with well
 Tapping: D8mm supply nozzle
 Connection: ½" nipple pipe thread

INSTALLATION DIMENSIONS

	A362	A382
Height to bowl (H2):	600mm	800mm
Pipe stand height (H3):	660mm	860mm
Overall height (H1):	1560mm	1760mm
Well:	D200 x 900mm	D200 x 900mm

SHIPPING

Dimensions, H-W-D: 1560 x 275 x 348mm/ 1760 x 275 x 348mm
 Weight: 8,5kg/ 9,0kg - complete with well

VALVE

FROSTLINE® self-emptying sliding valve
 Capacity: 9 l/min. at 2-4 bar
 connection pressure: 2-6 bar
 O-rings: NBR - 1 x D9x1,5 70sh, 2 x D6x1,5 70sh

MODELS

A362	69.48.91.360	Automatic Drinking System 60cm
A382	69.48.91.380	Automatic Drinking System 80cm

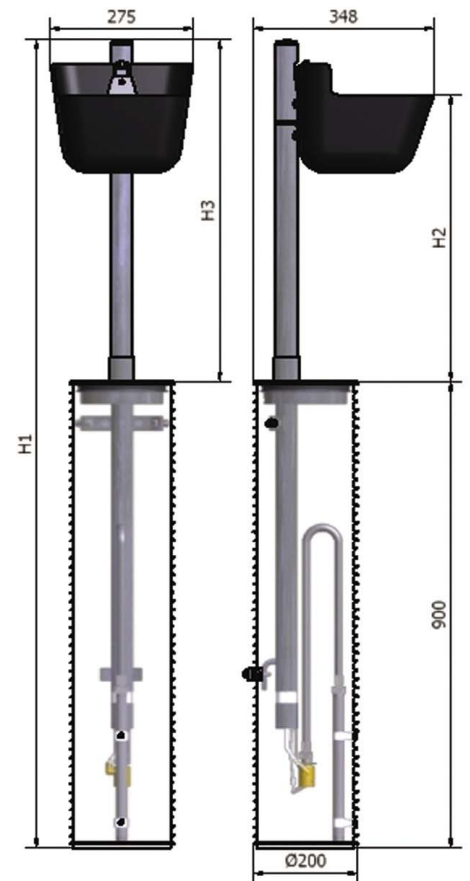

OPERATION OF THE VALVE

The system is provided with a 3-way self-emptying sliding valve. When the system is not in use, the valve and riser pipe are emptied of water that might otherwise freeze. The drinking system and thus the valve and riser pipe are frost-proof as long as the water supply line for the system is at frost-free depth.

RECOMMENDATION

A automatic drinking system can provide fresh, cool drinking water all year round for 10-12 horses but we recommend installation of two systems with a minimum distance of 5 meters between the two, when more than one horse is to be served in order to secure that all horses have access to the water. This means that the two systems can serve a total of 20-24 horses.

