



DUO CLASSIC

Frostline Classic is the ORIGINAL frost-free water tap from the DUO series. Classic was created based on a vision to outcompete obsolescence. The tap is a fusion of streamlined quality and timeless design. It is handmade in Denmark and crafted from recyclable stainless steel of the highest quality, ensuring enjoyment for many years.

DUO CLASSIC

Frostline is manufactured in Denmark and has more than 25 years of experience. We offer a wide range of frost-free outdoor products in beautiful design, high quality and with great functionality.

The water tap works by a self-draining mechanical valve empties the water tap after use, ensuring fresh water all year round. Our products do not require use of electricity to ensure frost-free, and made in stainless steel - and is therefor environmentally friendly in every way. The one handle grip provides a simple operation and good comfort. The product is delivered complete with a well.

We recommend

It is recommended to use supply water pipes of PEM pipes of 25mm or larger.

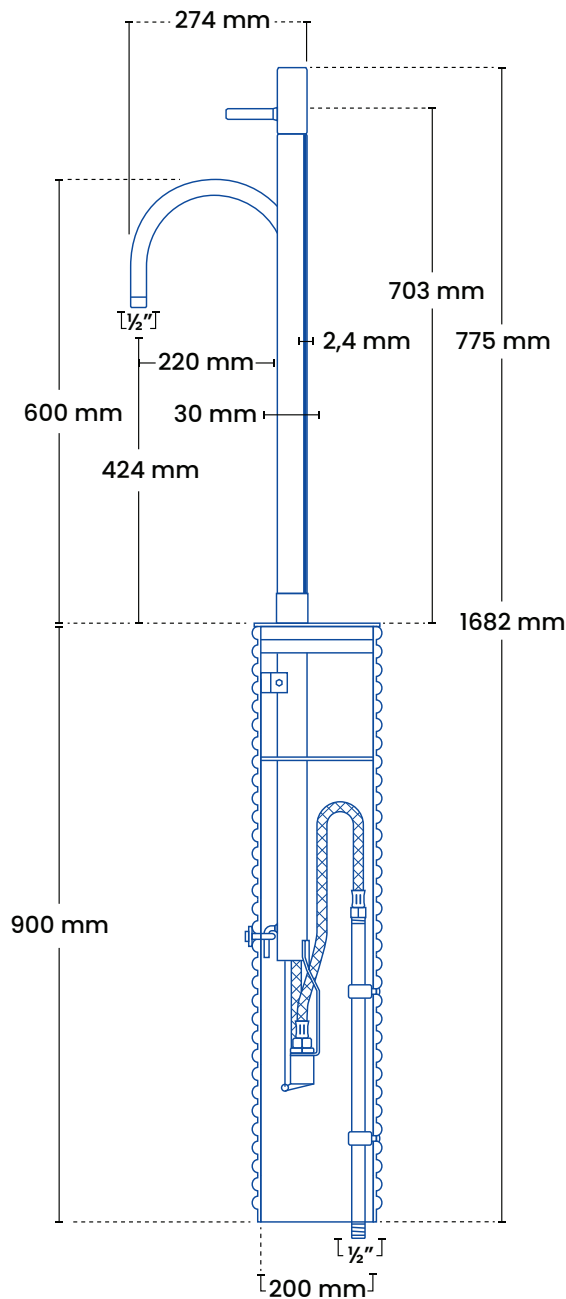

Glassblown

Specifications

Installation

Tap height	430 mm
Tap depth	217 mm
Stand height	795 mm
Grip height	715 mm
Nozzle height	630 mm
Connection	1/2"
Hose connection	1/2"

Product dimension

Total height	1695 mm
Total width	270 mm
Well	D200 x 900 mm
Dimension	D30 mm
Thickness	2 mm

Packaging

Dimension	174x20x38 cm
Weight	10,5 kg, complete w. well

Frostline valve

Capacity	18-23 l/min. at 2-4 bar
O-rings	1 pc. D14x1,5 70sh 2 pc. D10x2,5 70sh

Models

Product	VVSno.	Description
F004	743480.004	Classic 23 G water tap

Optional

Product	VVSno.	Description
F512	743480.916	Classic well ring D60
F530	743489.916	Tap connector
F921	743489.004	Extension hose 300 mm