



F102 · F122

## DUO L FREE-STANDING WATER POINT

The Duo L series is a frost-free solution in an exclusive and timeless design. The product is made of glass-blown stainless steel and is prepared so that a garden hose can be mounted on the spout.

It is suitable for outdoor areas such as gardens, golf courses, parks and urban spaces, where there is a need for a drinking water-approved outdoor water point that can be used all year round.

# DUO L FREE-STANDING WATER POINT

Frostline is manufactured in Denmark and today has more than 25 years of experience. We offer a wide range of frost-free outdoor products in beautiful design, high quality and with great functionality. The park water dispenser works by a self-draining mechanical valve emptying the water dispenser of water after use, which ensures fresh water all year round. Our products do not require the use of electricity to ensure frost-freeness, and are made of stainless steel – so environmentally friendly in every way. The water dispenser is a handle, which provides simple operation and good comfort. The product is delivered complete with well.

## We recommend

It is recommended to use a supply water line of PEM pipe of 25mm or larger.

## Specifications

### Installation target

Tap height	519 mm
Tap depth	146 mm
Stand height	790 mm
Height of handle	784 mm
Height of spout	655 mm
Connection	3/4"
Hose connection	1/2"

### Product dimensions

Total height	1691 mm
Total width	241 mm
Well	D160 x 900 mm
Dimension	D25 mm
Good thickness	2 mm

### Packaging

Measure H-B-D	184x20x30 cm
Weight	10 kg with complete well

### Frostline valve

Capacity (Duo L30)	28-32 l/min. at 2-4 bar
Capacity (Duo L9)	6-9 l/min. at 2-4 bar
O-rings	8x3mm - NBR shore 70

### Models

Product	plumbing no.	Description
F102	743480.304	Duo L 30 water tap
F102-1	743485.304	Duo L 30 self-closing water tap
F122	743480.314	Duo L 9 water tap
F122-1	743485.314	Duo L 9 water tap self-closing

### Options

Product	plumbing no.	Description
F510	743480.926	Duo Brøndring D60
F520	743489.936	Lock tube for Duo
F530	743489.916	Quick coupling, glass-blown steel
F921	743489.004	Extension hose with fittings

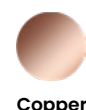
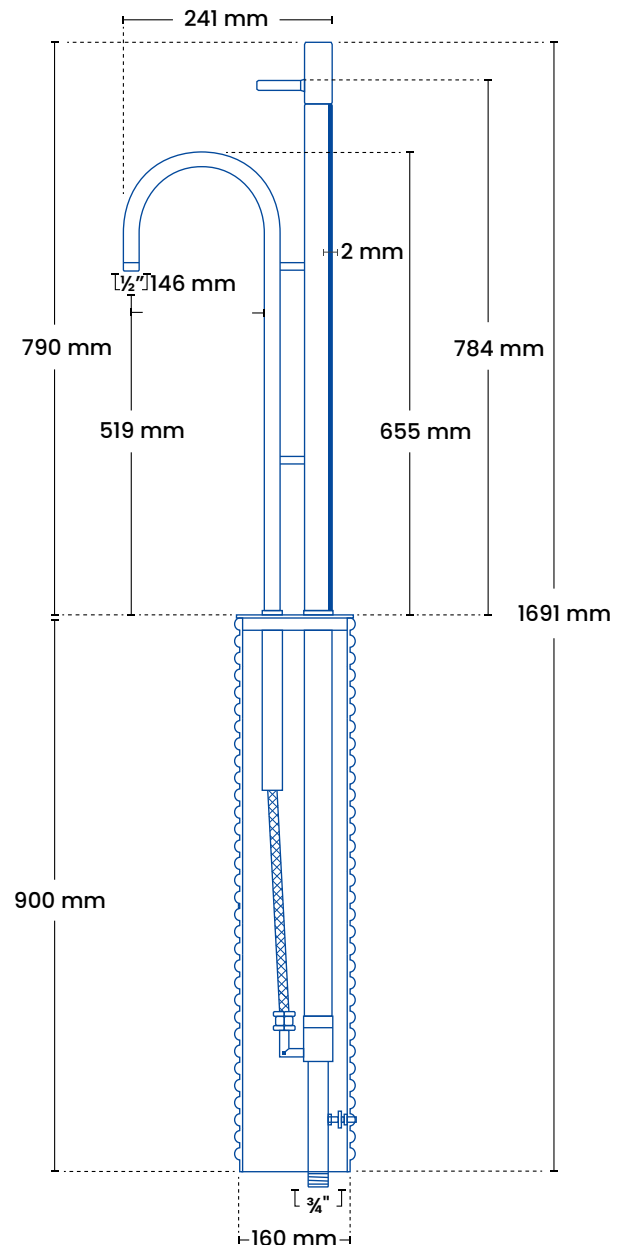

### Note:

Polished or copper surface must be specially produced.



GODKENDT  
TIL DRILLEKVVAND

GDV approval no.:  
04/00116

**With a well** For function and guarantee, there is a requirement for a frost-free water supply all year round, that the well is buried so that the top is in the ground and that the well is dry at all times. Below 5 degrees, no hose nozzles or equipment may be fitted.