



DRINKING SYSTEM

Frost-free drinking system for horses, cows and other animals. The machine in stainless steel is a reliable and environmentally friendly quality product that ensures fresh water and minimal work regardless of the season.

DRINKING SYSTEM

Frostline is manufactured in Denmark and has more than 25 years of experience. We offer a wide range of frost-free outdoor products in beautiful design, high quality and with great functionality.

The drinking system works by a self-draining mechanical valve empties the water tap after use, ensuring fresh water all year round. Our products do not require use of electricity to ensure frost-free, and made in stainless steel - and is therefore environmentally friendly in every way. The one handle grip provides a simple operation and good comfort. The product is delivered complete with a well.

We recommend

It is recommended to use supply water pipes of PEM pipes of 25mm or larger. Gaskets can be changed without digging up the well. The stand can be pulled up from the well and valve separated, after which the o-rings can be replaced.

Specification

Installation

Product	A342	A362	A382
Cup height (H1)	400 mm	600 mm	800 mm
Total height (H2)	460 mm	660 mm	860 mm
Total height (H3)	1360 mm	1560 mm	1760 mm
Connection	½"	½"	½"

Product dimension (same for all models)

Total width	275 mm
Well	D200 x 900 mm
Dimension	D42,5 mm
Thickness	3,2 mm

Packaging

Product	A342	A362
Dimension	136x27,5x34,8 cm	156x27,5x34,8 cm
Weight	8 kg, complete w. well	8,5 kg, complete w. well

Frostline valve

Capacity	9 l/min. at 2-6 bar
O-rings	NBR - 1 pc. D9x1,5 70sh, 2 pc. D6x1,5 70sh

Models

Product	VVSno.	Description
A342	694891.340	Drinking system 40 cm
A362	694891.360	Drinking system 60 cm
A382	694891.840	Drinking system 80 cm

Optional

Product	Description
A653	Reversal well

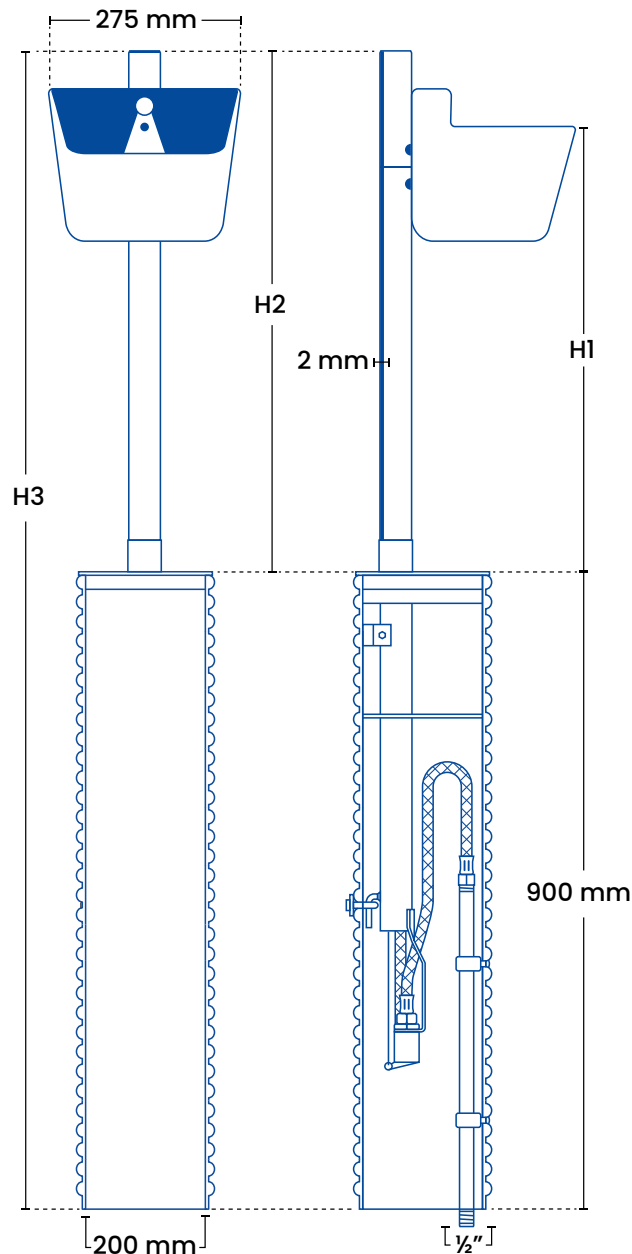

How it works

Drinking systems are especially suitable for fields or open barn systems. The cups are easy to operate, and the animals quickly learn that it is comfortable to press with the nose root instead of the muzzle. When the muzzle is free, the animals naturally drink from the water level - therefore we have chosen a cup with a wide and deep bottom that ensures a natural water level can be formed to drink from.