



F740 · F760

DUO WALL POST VALVE

Wall is an exclusive valve developed for the home and summer house. Similarly to the rest of Frostline's range, Wall is frost-proof, so frost cracks are avoided. The product is made of stainless steel, which ensures a minimum of maintenance and is prepared so that a garden hose can be mounted on the spout.

Wall and Elipse hose saddle, available in four different surface treatments: glass-blown steel, electro-polished steel, black and copper.

DUO WALL POST VALVE

Frostline is manufactured in Denmark and today has more than 25 years of experience. We offer a wide range of frost-free outdoor products in beautiful design, high quality and with great functionality.

Wall works by a self-draining mechanical non-return valve emptying the tap valve of water after use, which ensures fresh water all year round. Our products do not require the use of electricity to ensure frost-freeness, and are made of stainless steel - so environmentally friendly in every way. The water dispenser is a handle, which provides simple operation and good comfort.

Assembly

If connection with ½" thread is desired, shorten the copper pipe all the way down.

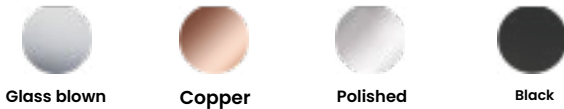

Glass blown

Copper

Polished

Black

Note: Polished, black or copper surface must be specially produced.

See also DUO hose holder, which matches perfectly with DUO Wall.



VA. approval no.:
ETA - VA 1.41/19463

Specifications

Installation target

Distance to cover plate	40-80 mm
Wall span	300-550 mm (cut to size) 150-350 mm (cut to size)
Bottling Connection	½" pipe thread D15 mm copper tube and ½"

Product dimensions

Total length	470-720 mm
Total width	90 x 150 mm
Thickness	2 mm

Packaging

Measure H-B-D	75x10x5 cm
Weight	1.6 kg

Frostline valve

Wall is equipped with a ceramic valve which has a built-in non-return valve, which ensures the same frost-freeness as the rest of Frostline's range.

Capacity	15 l/min. at 2-6 bar
----------	----------------------

Models

Product	plumbing no.	Description
F740	743458.154	Wall 300-550 mm
F740-01	743458.158	Wall 300-550 mm, copper
F740-02	743458.157	Wall 300-550 mm, polished
F740-S		Wall 300-550 mm, black
F760	743458.134	Wall 150-350 mm
F760-01	743458.168	Wall 150-350 mm, copper
F760-02	743458.167	Wall 150-350 mm, polished
F760-S		Wall 150-350 mm, black

Options

Product	plumbing no.	Description
F522		Locking tube for Wall
F530	743489,916	Lightning coupling, blown glass
F531	743489,918	Quick coupling, copper
F532	743489,917	Quick coupling, polished
F900	743489.104	Ellipse hose holder
F900-01	743489.108	Ellipse hose holder, copper
F900-02	743489.109	Ellipse hose holder, polished
F900-S		Ellipse hose holder, black
F921	743489.004	300 mm extension hose
F922	743489.064	600 mm extension hose
F923	743489.014	3000 mm hose
F929	743489.034	9000 mm hose

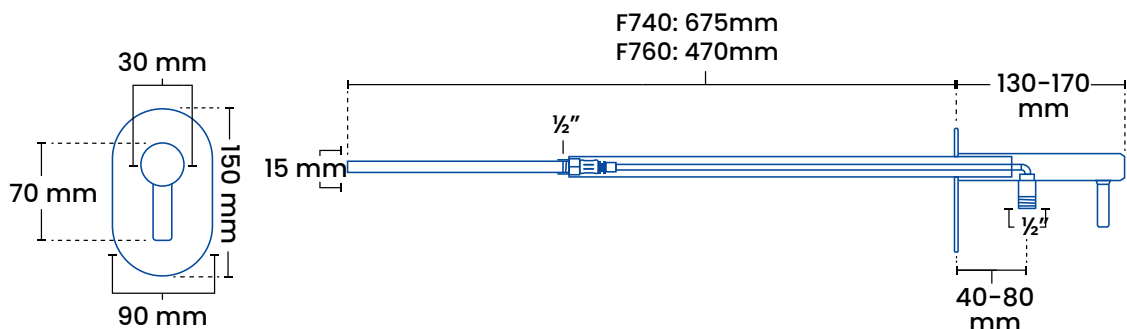

For wall mounting For function and warranty, there are requirements for a frost-free water supply all year round, that the product has a fall of at least 3% towards the outer wall and that a product in standard dimensions is used. Below 5 degrees, no hose nozzles or equipment may be fitted.