

3017

## PRO PUBLIC WALL MOUNTED TAP VALVE

The wall mounted tap from the PRO Public series is suitable for all public places where you need to be able to tap drinking water.

Comes with a handle which is a tempo stop. It has an expression that makes it look like a natural part of any facade.

Produced in solid and stainless steel and subsequently hand assembled in Denmark. Thus, you are guaranteed a frost-free solution that lasts year after year.

# PRO PUBLIC WALL MOUNTED TAP VALVE

Frostline is manufactured in Denmark and today has more than 25 years of experience. We offer a wide range of frost-free outdoor products in beautiful design, high quality and with great functionality. The tap works by a self-draining mechanical valve emptying the product of water after use, so you can shower all year round. Our products do not require the use of electricity to ensure frost-freeness, and are made of stainless steel, so environmentally friendly in every way.

## Important!

For the function, it is important that the pipe which is led through the wall falls 2-3 per mille towards the facade, so that the fixture can be emptied of water.

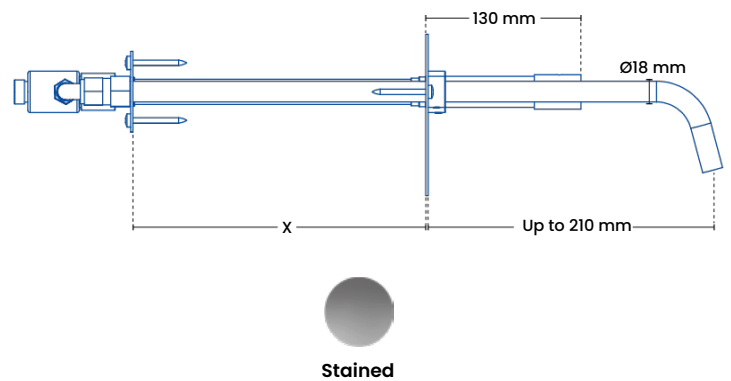
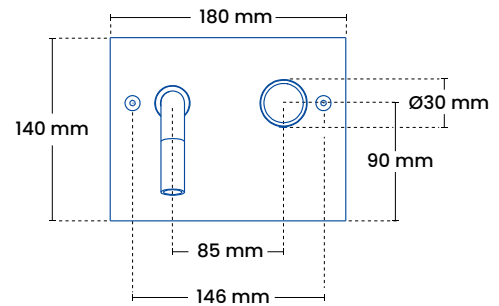

## Specifications

### Installation target

Luminaire center distance	153 mm
Back plate	W 180 mm x h 140 mm
Connection	1/2"

### Product dimensions

Total height	140 mm
Total width	180 mm
Tappet	Island 15
Armature	Island 27

### Packaging

Measure H-B-D	565 x 200 x 85 mm
Weight	2.5 kg

### Frostline valve

Capacity	9 l/min. 2-6 bars
----------	-------------------

### Models

Product	plumbing no.	Wall thickness
3017	743457.334	180 - 220 mm
3017	743457.364	300 - 340 mm
3017	743457.394	420 - 460 mm

See more variants in the price list.

**For wall mounting** For function and warranty, there are requirements for a frost-free water supply all year round, that the product has a fall of at least 3% towards the outer wall and that a product in standard dimensions is used. Below 5 degrees, no hose nozzles or equipment may be fitted.